

製品寸法図

[単位：mm]

SU-E2A*+SP-Y4*

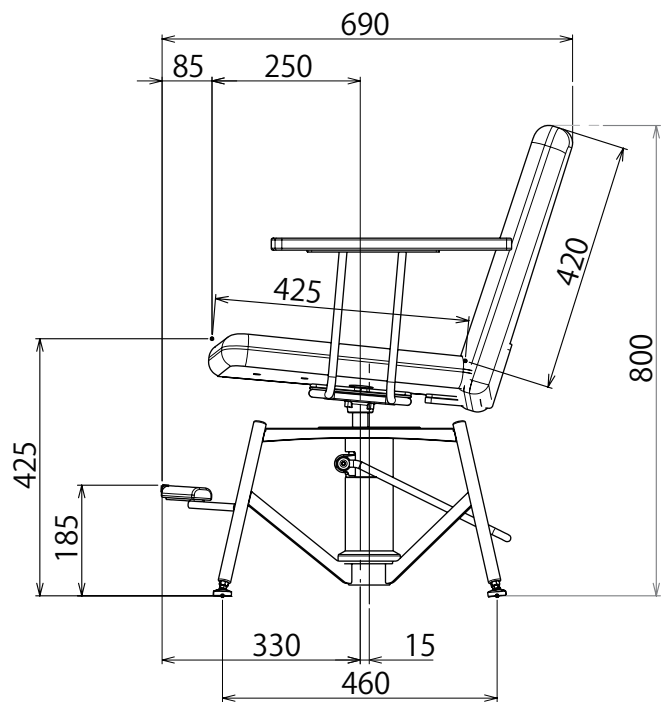
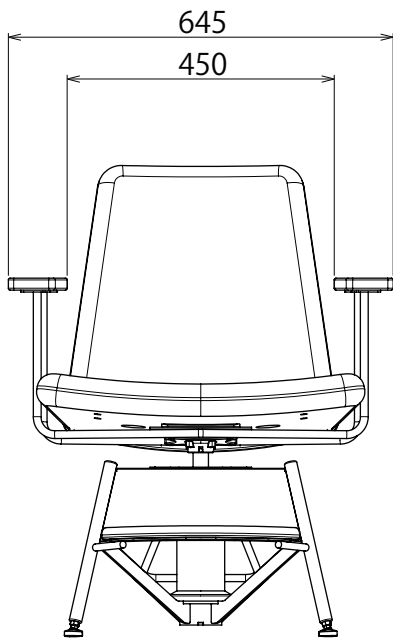
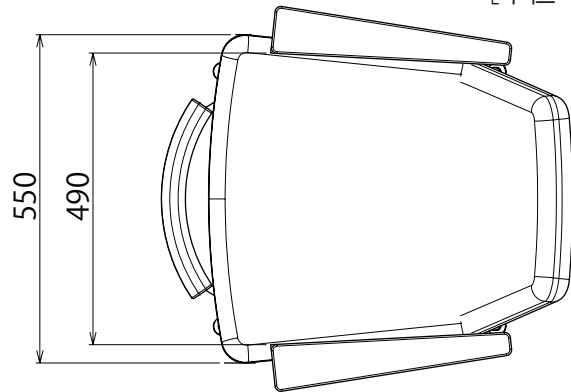

SU-E2A*S*+SP-YE*

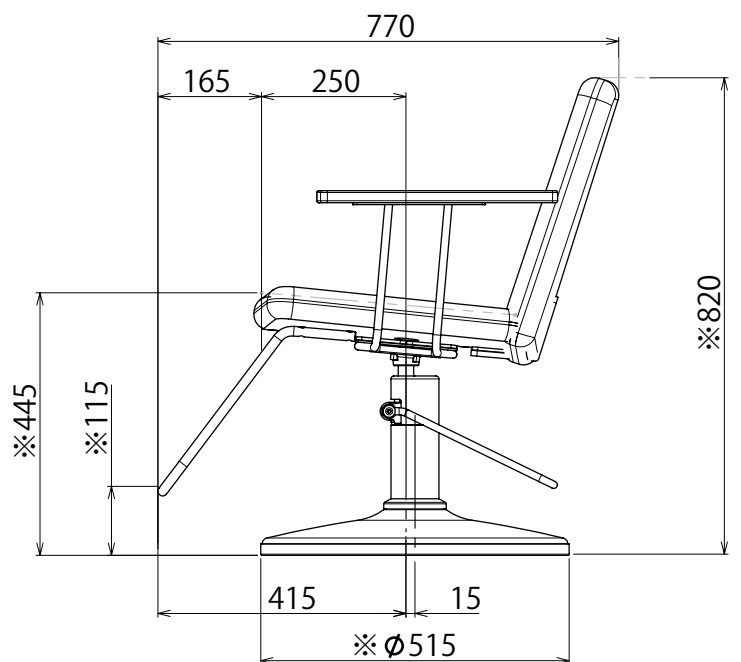
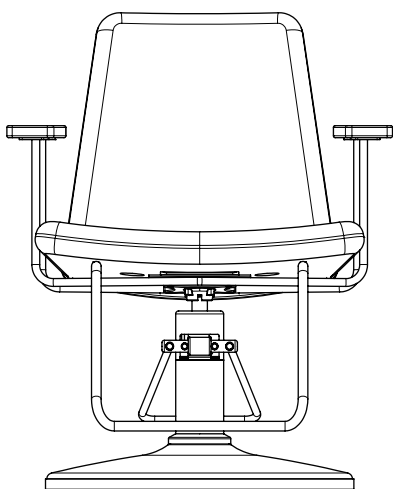

※印寸法は、組み合わせるチェアベースにより異なる寸法の為、参考寸法とする。

製品寸法図

[単位：mm]

SU-E2B*+SP-Y4*

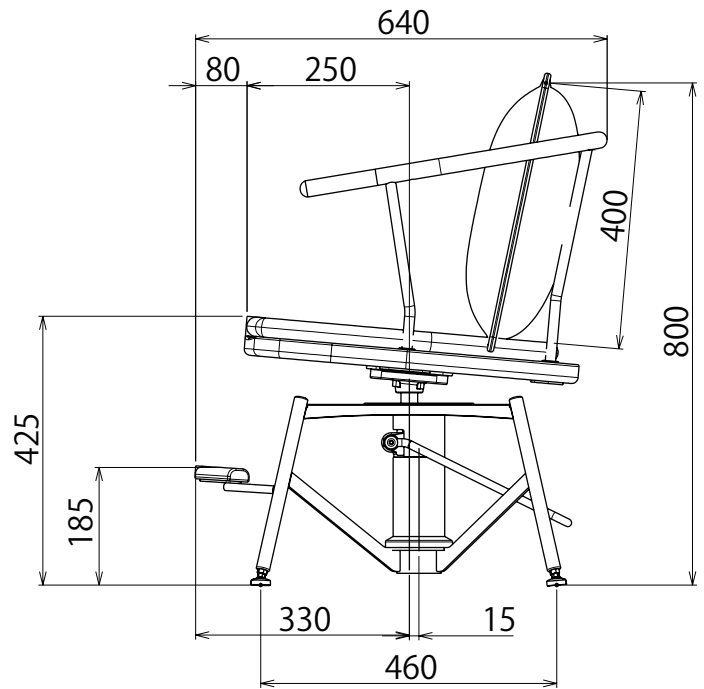
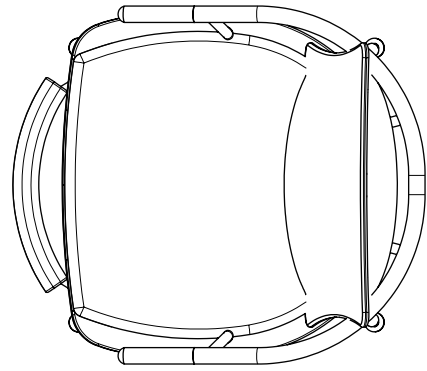
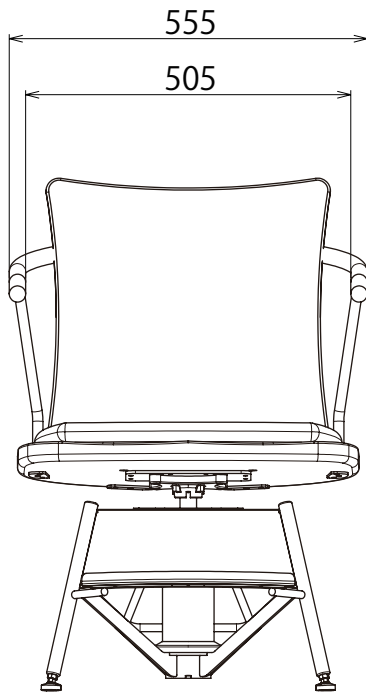

SU-E2BS*+SP-YE*

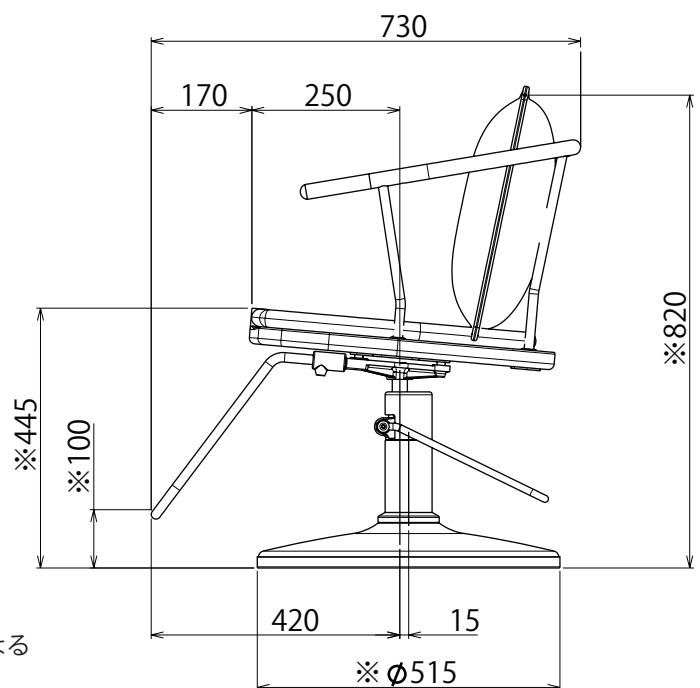
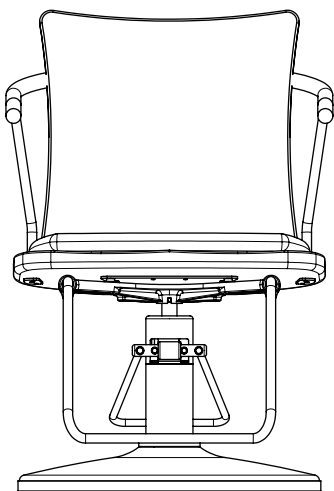

※印寸法は、組み合わせるチェアベースにより異なる寸法の為、参考寸法とする。

製品寸法図

[単位：mm]

SU-E2C*+SP-Y4*

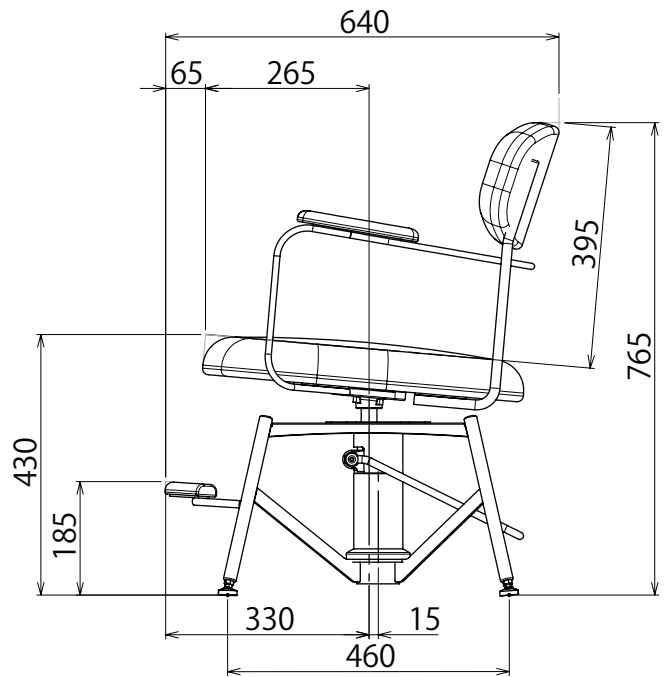
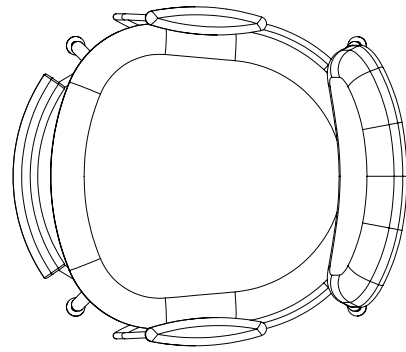
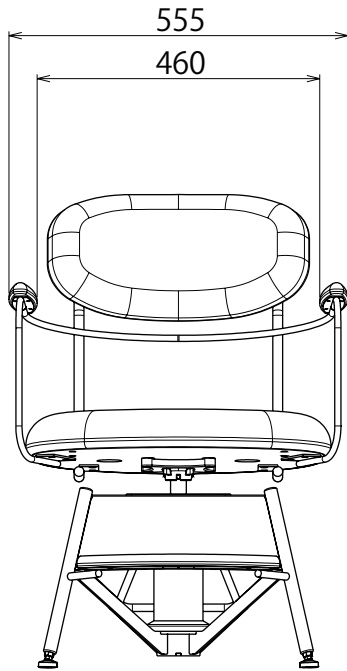

SU-E2C*S*+SP-YE*

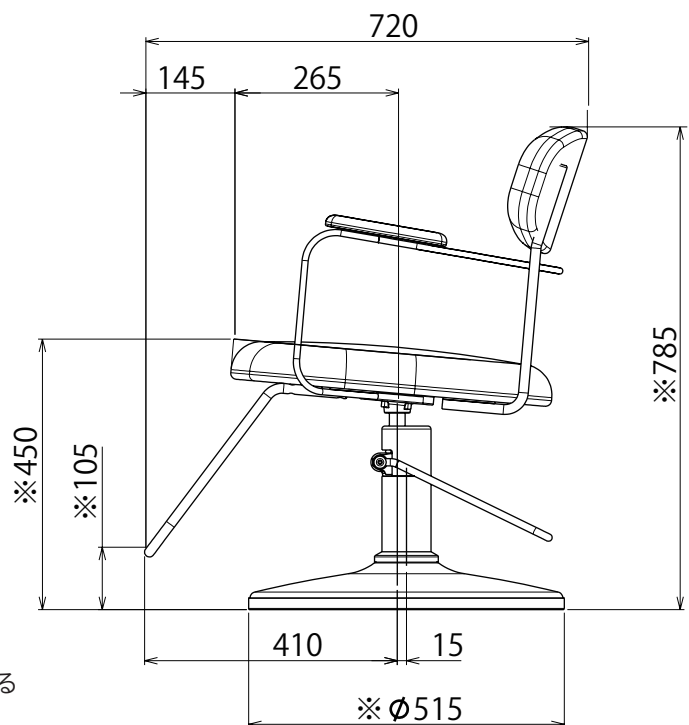
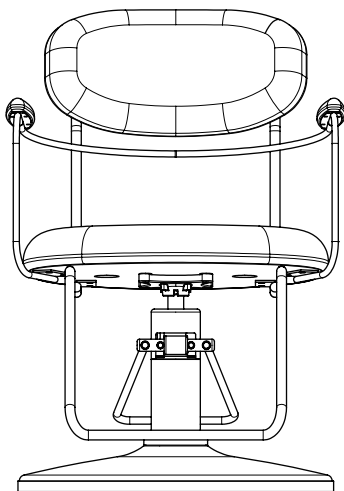

※印寸法は、組み合わせるチェアベースにより異なる寸法の為、参考寸法とする。